

NOTES: FOR ADDITIONAL DETAILS, PLEASE CONTACT VP CUSTOMER SERVICE  
 DIMENSIONS MARKED  ARE CONTROL DIMENSIONS

REVISIONS			
REV.	DESCRIPTION	DATE	APPROVED
A	INITIAL RELEASE	11-05-02	
B	CO 027 DRAFTING UPDATE	11-04-05	RICK C.
C	ECO 179	11-01-01	Rick C.

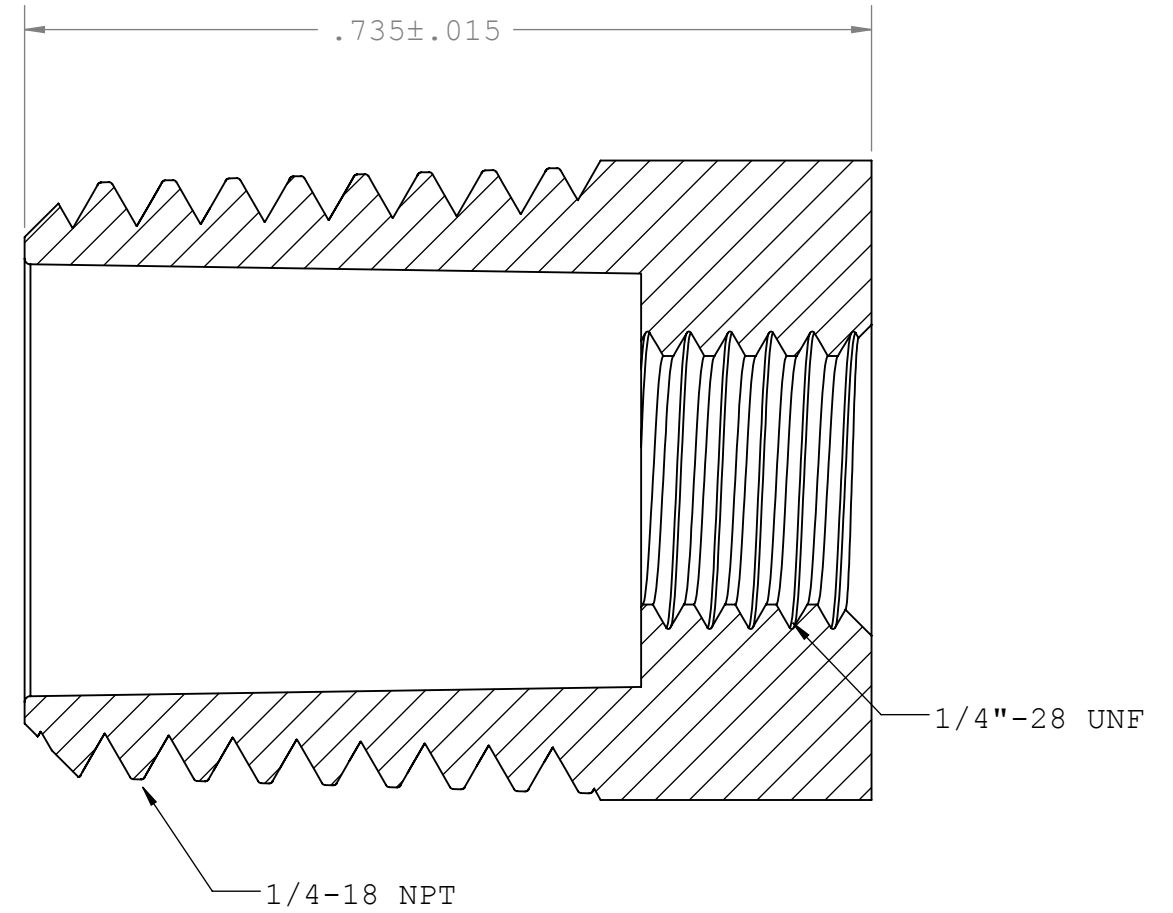

**SECTION A-A**

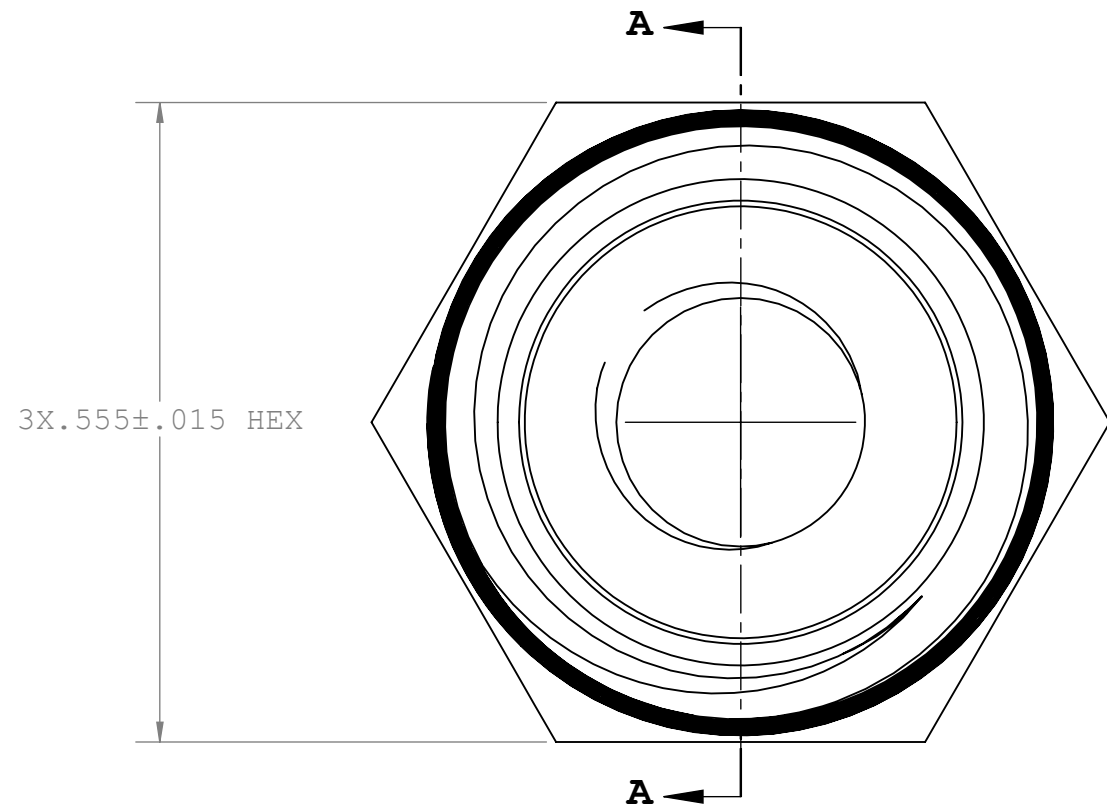
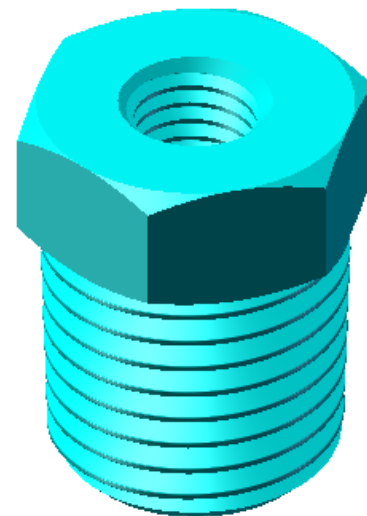

UNLESS OTHERWISE SPECIFIED DIMENSIONS ARE IN INCHES TOLERANCES ARE:		<b>VALUE PLASTICS, INC</b>			
FRACTIONS    DECIMAL    ANGULAR ±            .XX ±.01    ± 1° .XXX ±.005 .XXXX ±.001		PART NUMBER: 1402			
DO NOT SCALE DRAWING		DESCRIPTION: Reducer with 1/4-18 NPT Male Thread and 9/16 Hex to 1/4 UNF Female Thread			
DRAWN BY: chieup	DATE: 11/01/2010	SIZE: <b>B</b>	SCALE: NTS	VER:	DWG. NO. 1007449    REV C
MANAGER: RICKC		© 2010 VALUE PLASTICS, INC			SHEET: 1 OF 1

**FOR REFERENCE ONLY**