

NOTES: FOR ADDITIONAL DETAILS, PLEASE CONTACT VP CUSTOMER SERVICE  
 DIMENSIONS MARKED  ARE CONTROL DIMENSIONS

REVISIONS			
REV.	DESCRIPTION	DATE	APPROVED
A	INITIAL RELEASE	08-04-98	
B	CO 046 Drafting Update	06-19-06	Rick C.
C	ECO 122- Change Thru Hole ID to 0.125"	03-27-09	Rick C.

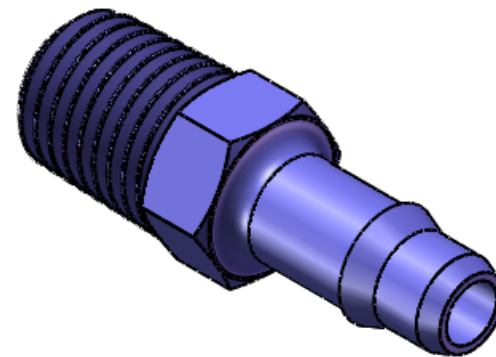
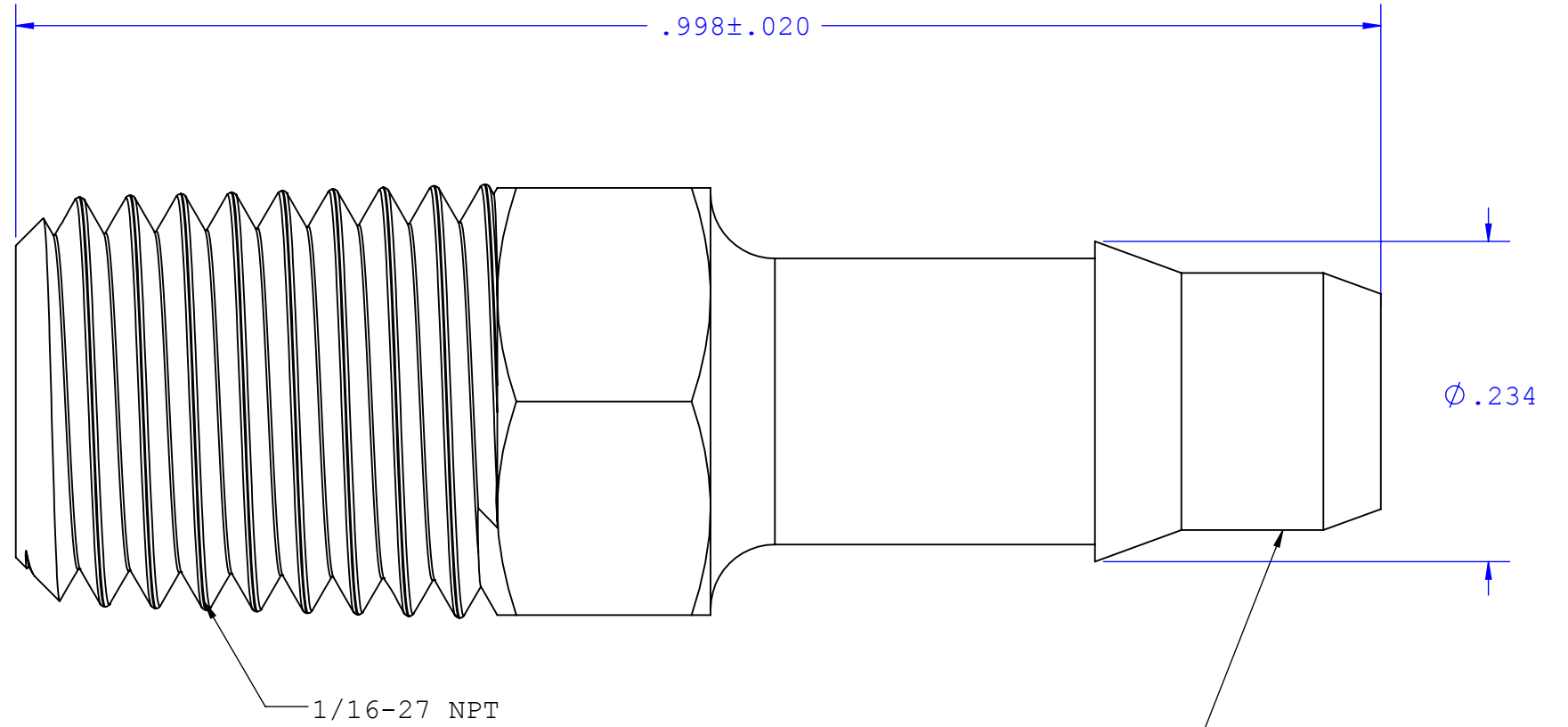
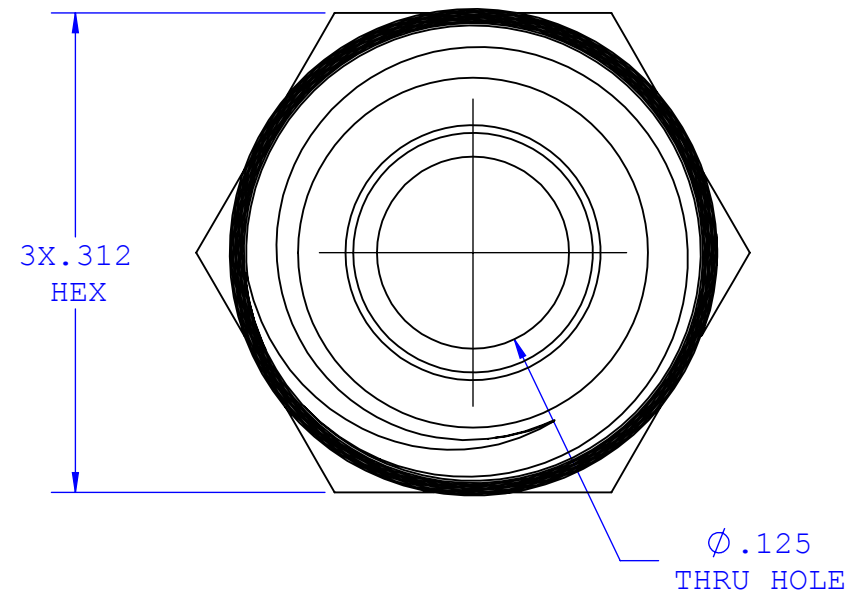

UNLESS OTHERWISE SPECIFIED DIMENSIONS ARE IN INCHES TOLERANCES ARE:		<b>VALUE PLASTICS, INC</b>			
FRACTIONS    DECIMAL    ANGULAR ±            .XX ±.01    ± 1° .XXX ±.005 .XXXX ±.001  DO NOT SCALE DRAWING		PART NUMBER: 16450			
DESCRIPTION: 1/16-27 NPT Thread with 5/16" Hex to 400 Series Barb, 3/16" (4.75mm) ID Tubing					
DRAWN BY: randy.sakurada	DATE: 3/27/2009	SIZE: <b>B</b>	SCALE: NTS	VER: 1008650	DWG. NO. 1008650
ENGINEERING MGR: R. Cairns		© 2009 VALUE PLASTICS, INC			REV C
				SHEET: 1 OF 1	

**FOR REFERENCE ONLY**