

NOTES: FOR ADDITIONAL DETAILS, PLEASE CONTACT VP CUSTOMER SERVICE
 DIMENSIONS MARKED \square ARE CONTROL DIMENSIONS

| REVISIONS | | | |
|-----------|---------------------------------------|----------|----------|
| REV. | DESCRIPTION | DATE | APPROVED |
| A | INITIAL RELEASE | 07-01-98 | |
| B | CO 046 Drafting Update | 06-20-06 | Rick C. |
| C | ECO 130-Changing Hex Dimension for PP | 06-02-09 | Rick C. |

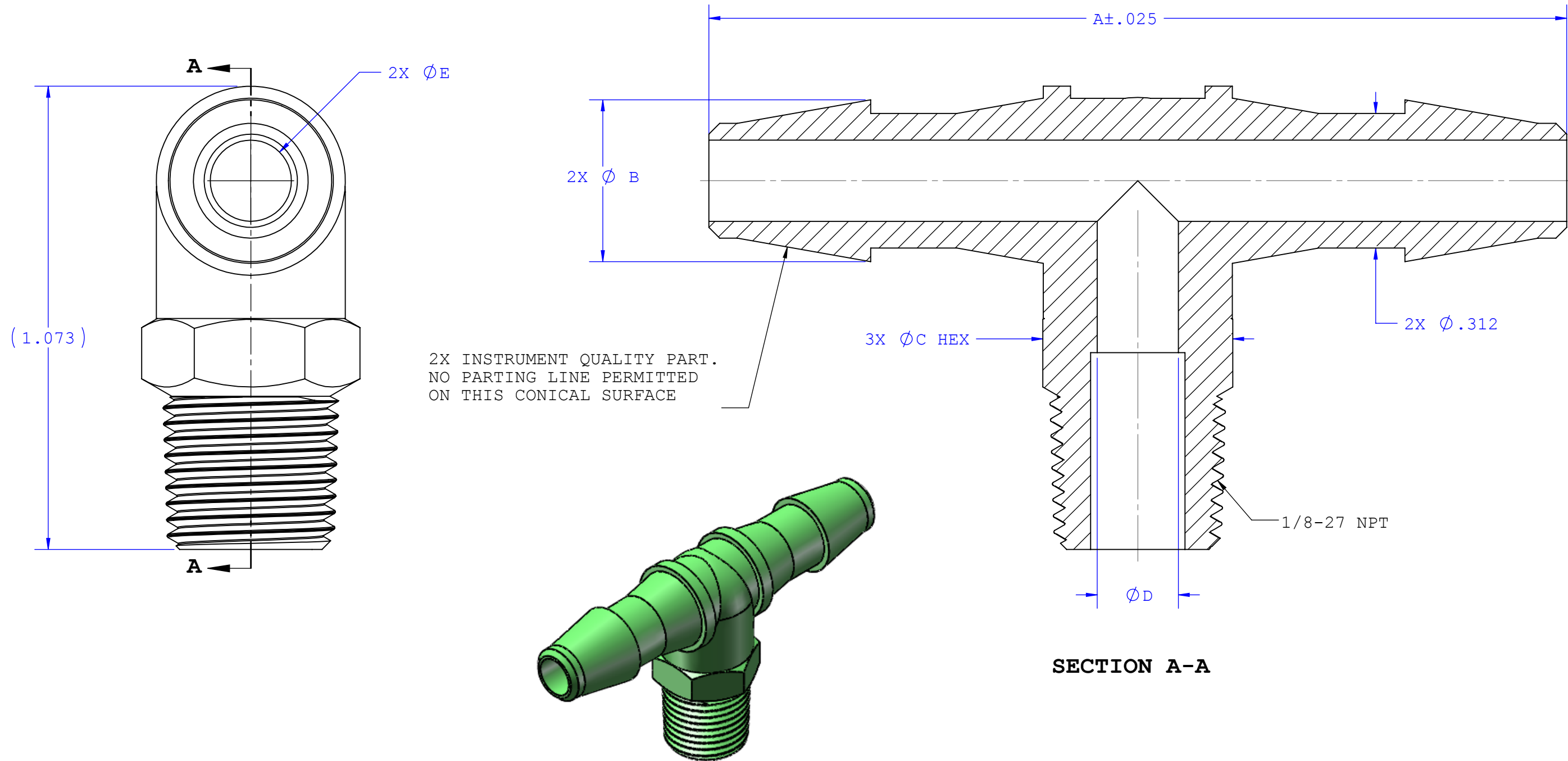

| Dimension | Material Specific Tolerances | | | | | | | |
|-----------|------------------------------|-------|-------|-------|-------|-------|-------------|-------|
| | Acetal | Nylon | PP | ABS | PC | PVC | Polysulfone | PVDF |
| A | 1.988 | 1.988 | 1.988 | 1.988 | 1.988 | 1.988 | 1.988 | 1.964 |
| B | .375 | .375 | .375 | .375 | .375 | .375 | .375 | .369 |
| C | .440 | .440 | .440 | .440 | .440 | .440 | .440 | .435 |
| D | .188 | .176 | .180 | .188 | .188 | .188 | .188 | .184 |
| E | .188 | .176 | .175 | .188 | .188 | .188 | .188 | .174 |

| | | | | | |
|---|-------------------|---|---------------|------------------|---------------------|
| UNLESS OTHERWISE SPECIFIED DIMENSIONS ARE IN INCHES TOLERANCES ARE: | | VALUE PLASTICS, INC | | | |
| FRACTIONS DECIMAL ANGULAR ± .XX ±.01 ± 1° .XXX ±.005 .XXXX ±.001 | | PART NUMBER: 18T260 | | | |
| DO NOT SCALE DRAWING | | DESCRIPTION: 1/8-27 NPT Thread Tee with 7/16" Hex to 200 Series Barb, 1/4" (6.25mm) ID Tubing | | | |
| DRAWN BY: randy.sakurada | DATE: 6/2/2009 | SIZE: B | SCALE: NTS | VER: 1008666 | DWG. NO. 1008666 |
| ENGINEERING MGR: Rick Cairns | | © 2009 VALUE PLASTICS, INC | | | REV C |
| | | | | SHEET: 1 OF 1 | |

FOR REFERENCE ONLY