

NOTES: FOR ADDITIONAL DETAILS, PLEASE CONTACT VP NEW PRODUCT DEVELOPMENT  
 DIMENSIONS MARKED  $\varnothing$  ARE CONTROL DIMENSIONS

REVISIONS			
REV.	DESCRIPTION	DATE	APPROVED
A	Initial Release	07-27-00	
B	CO 018 Drafting Update	07-11-05	R. Cairns
C	ECO 176, O-Ring	10-8-10	S.N.R
D	ECO 198, Drafting	06-23-11	R. Cairns

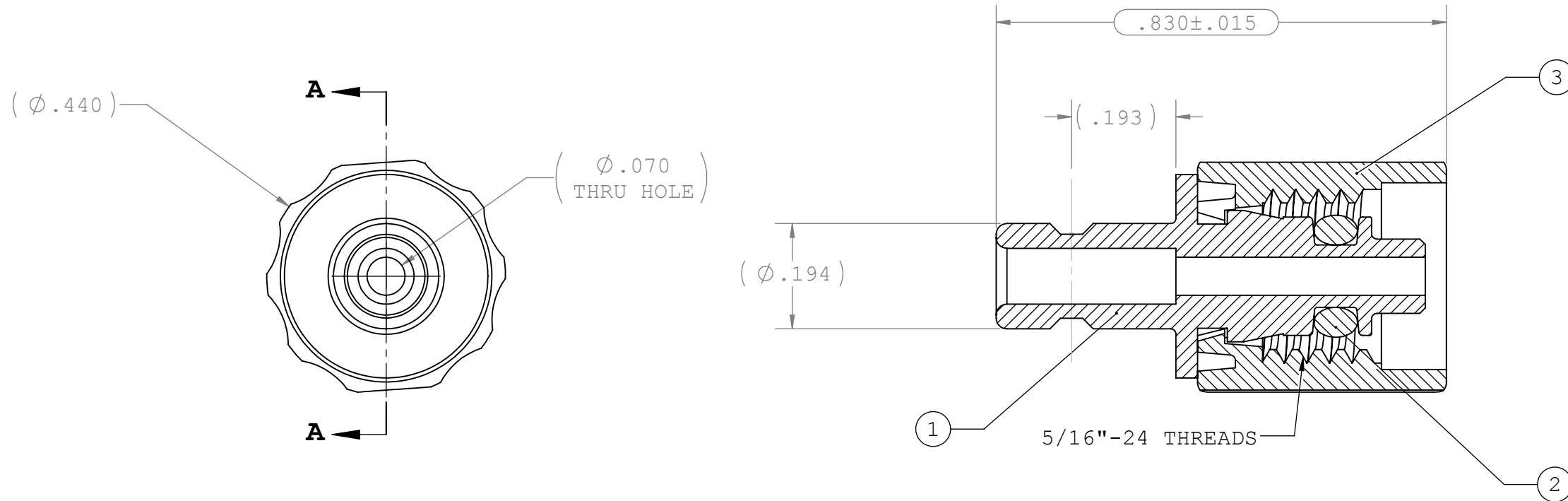

**SECTION A-A**

AQL SPECIFICATIONS  
 1. VISUAL INSPECTION FOR DAMAGE

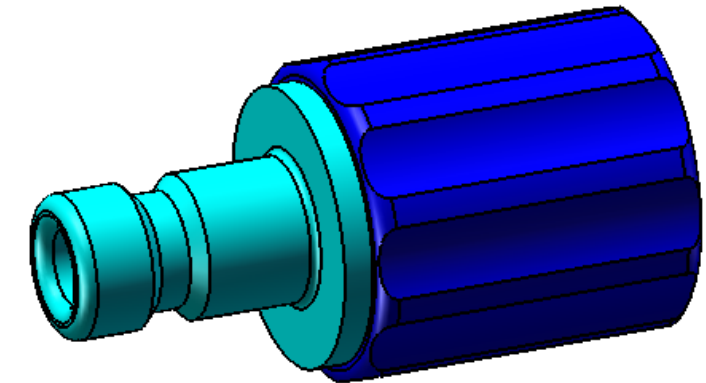

Assembly Part Number	Item 1 (BPI055) Material	Item 2 (AC1000113) Material	Item 3 (BPN) Material	Description
BPAM-001	White Nylon	Black BunaN Rubber	Black Nylon	BPAM Black Nylon over White Nylon

UNLESS OTHERWISE SPECIFIED DIMENSIONS ARE IN INCHES TOLERANCES ARE:		<b>VALUE PLASTICS, INC</b>			
FRACTIONS ±	DECIMAL . XX ±.01 .XXX ±.005 .XXXX ±.001	ANGULAR ± 1°	PART NUMBER: BPAM		
DO NOT SCALE DRAWING		DESCRIPTION: Blood Pressure Monitor Connector Bayonet to Internal 5/16-24 UNF Thread and O-Ring			
DRAWN BY: T. Whitaker	DATE: 10-5-10	SIZE: <b>B</b>	SCALE: NTS	VER: 1006852	REV: D
MANAGER: R. Narayanan		© 2011 VALUE PLASTICS, INC			SHEET: 1 OF 1