

NOTE: FOR MORE DETAILS SEE YOUR V.P. CUSTOMER SERVICE REP.

REVISIONS			
REV.	DESCRIPTION	DATE	APPROVED
A	INITIAL RELEASE	05-20-98	
B	CO 027 Drafting Update	10-04-05	Rick C.

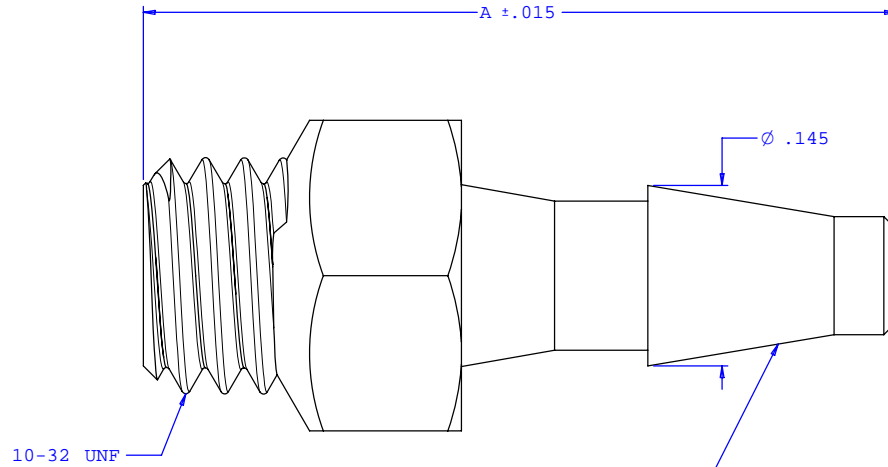

INSTRUMENT QUALITY PART. NO PARTING LINE PERMITTED ON THIS CONICAL SURFACE

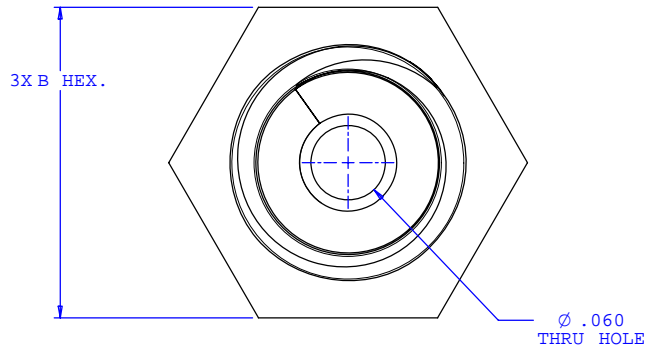
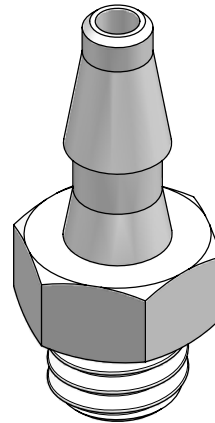

Dimension	Material Specific Tolerances							
	Acetal	Nylon	PP	ABS	PC	PVC	Polysulfone	J1A
A	.606	.606	.589	.606	.606	.606	.606	.606
B	.250	.250	.244	.250	.250	.250	.250	.250
C								
D								
E								
F								

UNLESS OTHERWISE SPECIFIED DIMENSIONS ARE IN INCHES TOLERANCES ARE:		VALUE PLASTICS, INC.	
FRACTIONS ±	DECIMALS ±	ANGULAR ±1°	PART NUMBER: D
.XX ±.01	.XXX ±.005	.XXXX ±.001	DESCRIPTION: 10-32 UNF Thread with 1/4" Hex to Classic Series Barb, 3/32" (2.25 mm) ID Tubing
DO NOT SCALE DRAWING		SIZE: B	SCALE: NTS
DRAWN BY: Frank Lombardi	DATE: 09-01-05	DRAWING NUMBER: 1007462	REV. B
Engineer / Manager: Rick Cairns		© 2005 VALUE PLASTICS, INC. SHEET: 1 OF 1	

FOR REFERENCE ONLY