

NOTES: FOR MORE DETAILS SEE YOUR V.P. SERVICE REP.

REVISIONS			
REV.	DESCRIPTION	DATE	APPROVED
A	INITIAL RELEASE	01/31/08	R. Cairns
B	UPDATED ASSEMBLY DRAWING	03/13/09	R. Cairns
C	ECO-132 New Weld Joint Design	10/05/09	R. Cairns

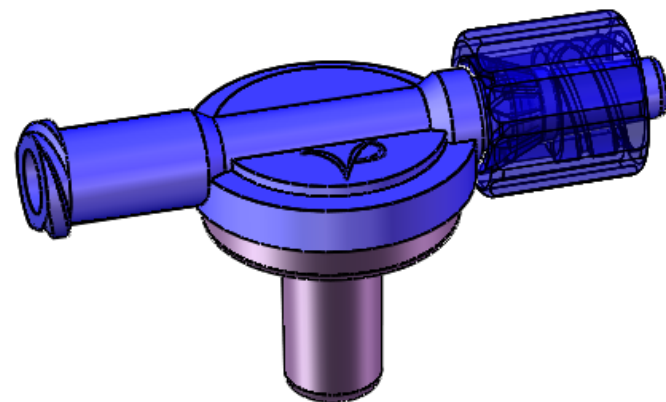
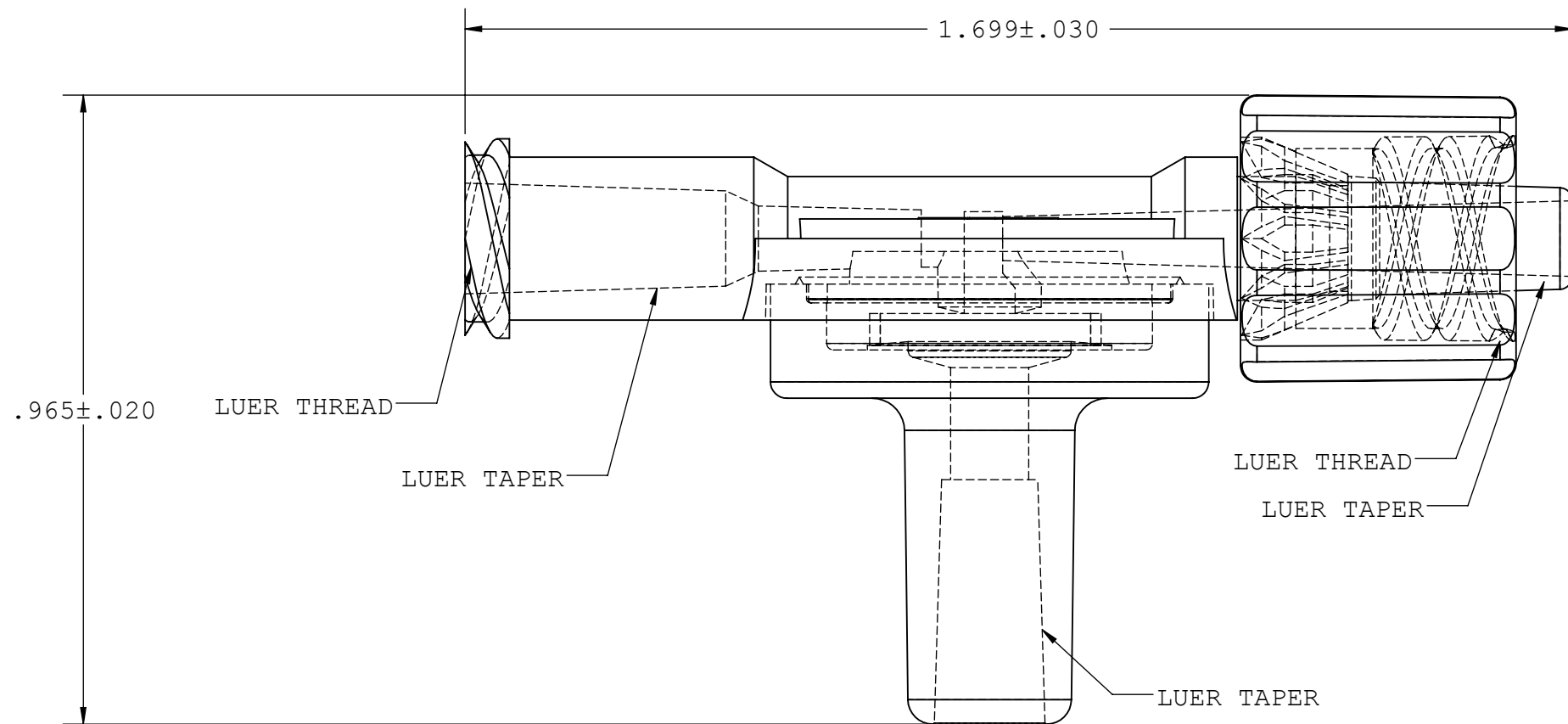
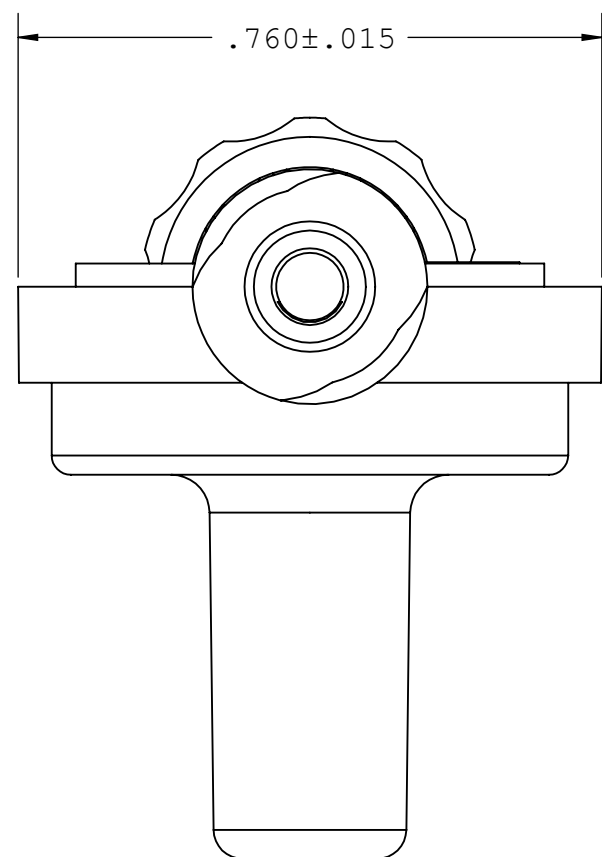

UNLESS OTHERWISE SPECIFIED DIMENSIONS ARE IN INCHES TOLERANCES ARE:		VALUE PLASTICS, INC			
FRACTIONS ±	DECIMAL . XX ±.01 .XXX ±.005 .XXXX ±.001	ANGULAR ± 1°	PART NUMBER: DCV125		
DO NOT SCALE DRAWING			DESCRIPTION: Double Check Valve, Style 125		
DRAWN BY: Michele Schenk	DATE: 10/6/2009	SIZE: B	SCALE: NTS	VER: 	DWG. NO. 1012666
ENGINEERING MANAGER: R. Cairns		© 2008 VALUE PLASTICS, INC			REV C
				SHEET: 1 OF 1	

FOR REFERENCE ONLY