

REVISIONS			
REV.	DESCRIPTION	DATE	APPROVED

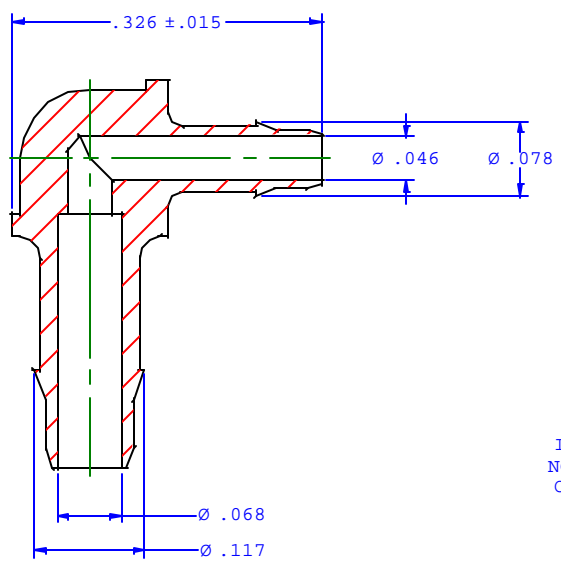

SECTION A-A

INSTRUMENT QUALITY PART.
NO PARTING LINE PERMITTED
ON THIS CONICAL SURFACE.
2 PLACES

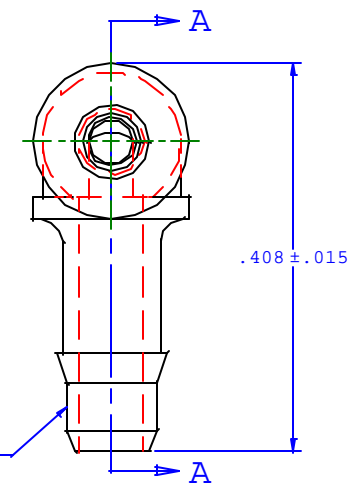

UNLESS OTHERWISE SPECIFIED DIMENSIONS ARE IN INCHES TOLERANCES ARE:		VALUE PLASTICS, INC.	
FRACTIONS ±	DECIMALS .XX ±.01 .XXX ±.005	ANGULAR ±1°	PART NUMBER: L420/410
DO NOT SCALE DRAWING		DESCRIPTION: Elbow Reduction Connector with 400 Series Barbs, 3/32" (2.25 mm) and 1/16" (1.5 mm) ID Tubing	
DRAWN BY: SUE CORAM	SCALE: NTS	DRAWING NUMBER:	REV.
DATE: 05/04/98	© 1998 VALUE PLASTICS, INC.		SHEET:

FOR REFERENCE ONLY