

NOTE: FOR MORE DETAILS SEE YOUR V.P.CUSTOMER SERVICE REP.

REVISIONS			
REV.	DESCRIPTION	DATE	APPROVED
A	INITIAL RELEASE	06-19-98	
B	CO 031 Drafting Update	Rick C.	01-17-06

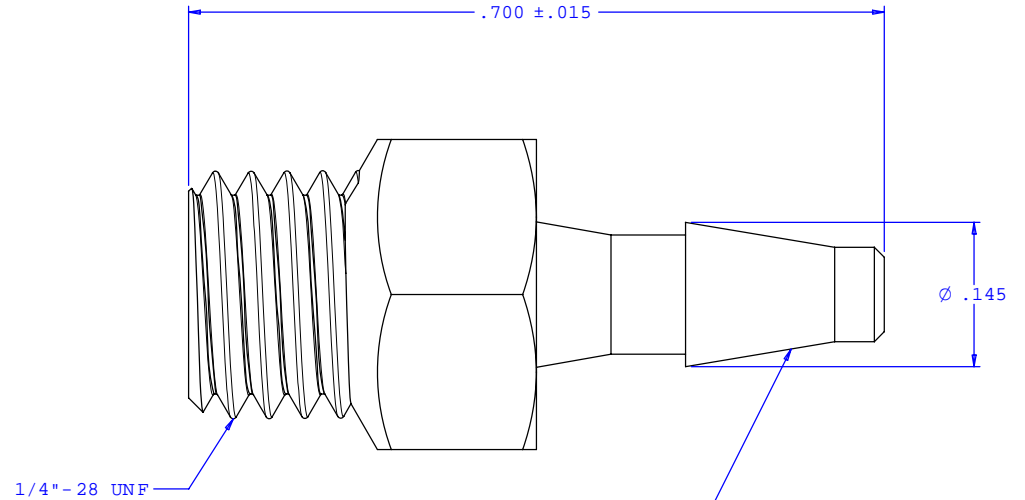

INSTRUMENT QUALITY PART. NO PARTING LINE PERMITTED ON THIS CONICAL SURFACE

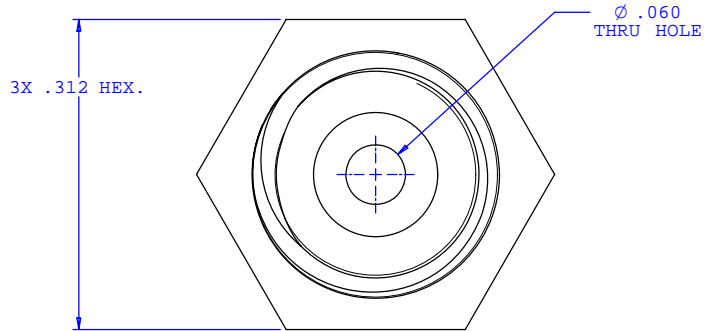
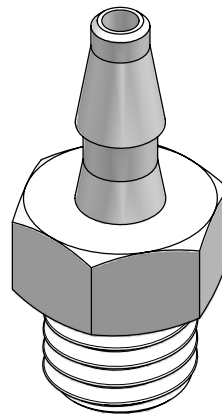

UNLESS OTHERWISE SPECIFIED DIMENSIONS ARE IN INCHES TOLERANCES ARE:		VALUE PLASTICS, INC.	
FRACTIONS ±	DECIMALS .XX ±.01 .XXX ±.005 .XXXX ±.001	ANGULAR ±1°	PART NUMBER: S20
DO NOT SCALE DRAWING		DESCRIPTION: 1/4-28 UNF Thread with 5/16" Hex to Classic Series Barb, 3/32" (2.25 mm) ID Tubing	
DRAWN BY: Frank Lombardi	DATE: 10-30-05	SIZE: B	SCALE: NTS
ENGINEER/ MANAGER: Rick Cairns	DRAWING NUMBER: 0123456789	REV. B	SHEET: 1 OF 1
© 2005 VALUE PLASTICS, INC.			

FOR REFERENCE ONLY