

NOTE: FOR MORE DETAILS SEE YOUR V.P. CUSTOMER SERVICE REP.

REVISIONS			
REV.	DESCRIPTION	DATE	APPROVED
A	INITIAL RELEASE	06-11-98	
B	CO 018 Drafting Update	08-18-05	RICKC

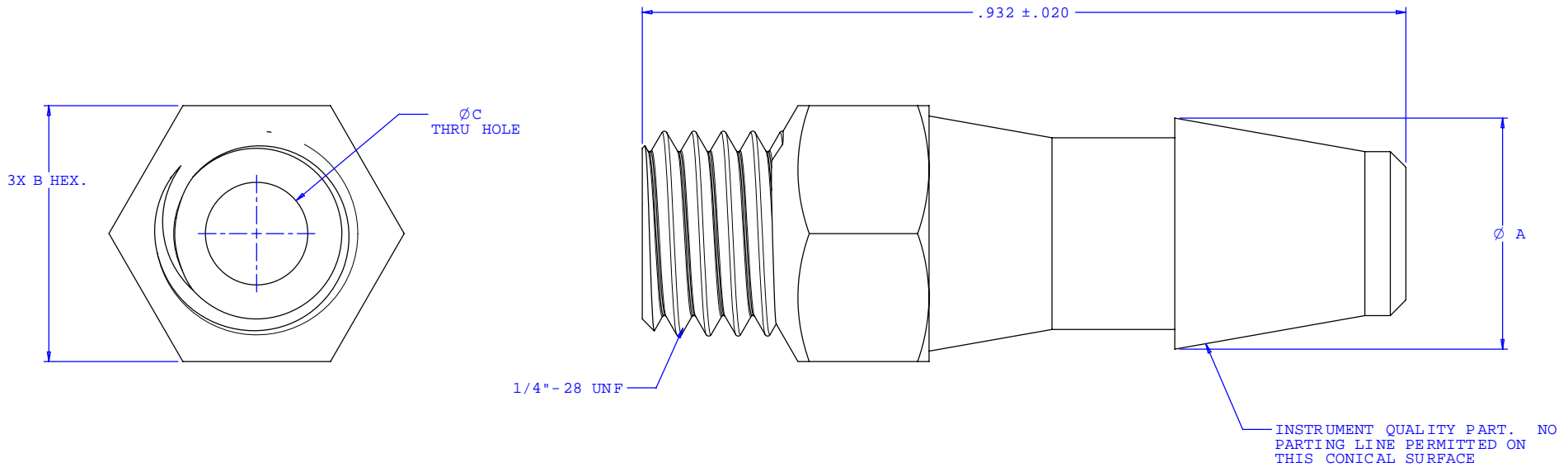

INSTRUMENT QUALITY PART. NO PARTING LINE PERMITTED ON THIS CONICAL SURFACE

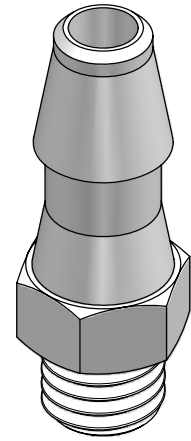

Dimension	Material Specific Tolerances							
	Acetal	Nylon	PP	ABS	PC	PVC	Polysulfone	J1A
A	0.282	0.275	0.277	0.282	0.282	0.282	0.282	0.271
B	.312	.307	.312	.312	.312	.312	.312	.307
C	.125	.121	.125	.125	.125	.125	.125	.121
D								
E								
F								

UNLESS OTHERWISE SPECIFIED DIMENSIONS ARE IN INCHES TOLERANCES ARE:		<b>VALUE PLASTICS, INC.</b>	
FRACTIONS ±	DECIMALS .XX ±.01 .XXX ±.005 .XXXX ±.001	ANGULAR ±1°	PART NUMBER: <b>S250</b>
DO NOT SCALE DRAWING		DESCRIPTION: 1/4-28 UNF Thread with 5/16" Hex to 200 Series Barb, 3/16" (4.75 mm) ID Tubing	
DRAWN BY: <b>Frank Lombardi</b>	DATE: <b>06-13-05</b>	SIZE: <b>B</b>	SCALE: <b>NTS</b>
Engineer/Manager: <b>Rick Cairns</b>		DRAWING NUMBER: <b>1006895</b>	REV. <b>B</b>
© 2005 VALUE PLASTICS, INC.		SHEET: 1 OF 1	

**FOR REFERENCE ONLY**