

NOTE: FOR MORE DETAILS SEE YOUR V.P.CUSTOMER SERVICE REP.

REVISIONS			
REV.	DESCRIPTION	DATE	APPROVED
A	INITIAL RELEASE	06-19-98	
B	CO 031 Drafting Update	01-17-06	Rick C.

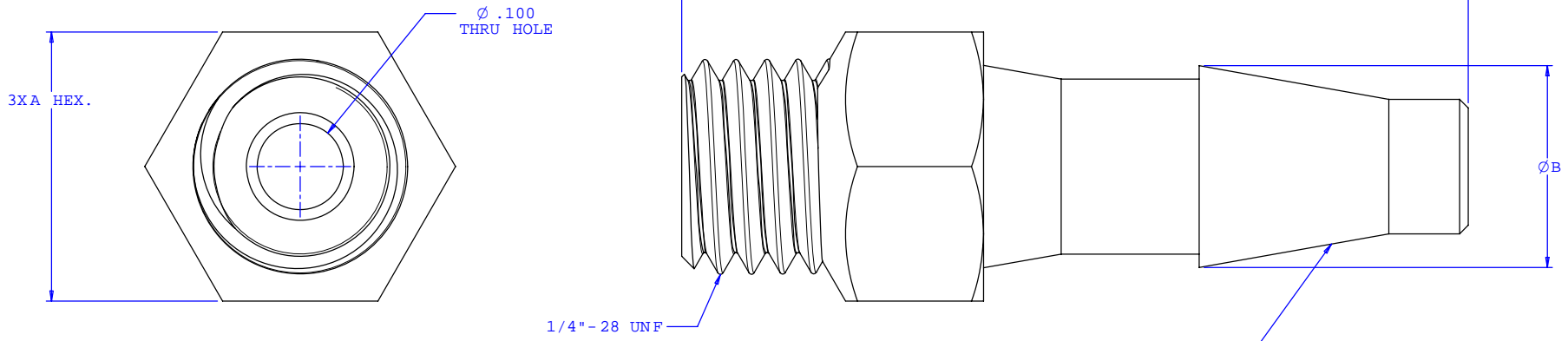

INSTRUMENT QUALITY PART. NO PARTING LINE PERMITTED ON THIS CONICAL SURFACE

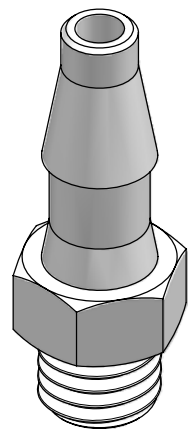

Dimension	Material Specific Tolerances							
	Acetal	Nylon	PP	ABS	PC	PVC	Polysulfone	J1A
A	.312	.309	.312	.312	.312	.312	.312	.309
B	.234	.228	.234	.234	.234	.234	.234	.228
C								
D								
E								
F								

UNLESS OTHERWISE SPECIFIED DIMENSIONS ARE IN INCHES TOLERANCES ARE:		VALUE PLASTICS, INC.	
FRACTIONS ±	DECIMALS .XX ±.01 .XXX ±.005 .XXXX ±.001	ANGULAR ±1°	PART NUMBER: S40
DO NOT SCALE DRAWING		DESCRIPTION: 1/4-28 UNF Thread with 5/16" Hex to Classic Series Barb, 5/32" (4 mm) ID Tubing	
DRAWN BY: Frank Lombardi	DATE: 10-29-05	SIZE: B	SCALE: NTS
Engineer/Manager: Rick Cairns		DRAWING NUMBER: 1007771	REV. B
© 2005 VALUE PLASTICS, INC.		SHEET: 1 OF 1	

FOR REFERENCE ONLY