

NOTE: FOR MORE DETAILS SEE YOUR V.P. CUSTOMER SERVICE REP.

REVISIONS			
REV.	DESCRIPTION	DATE	APPROVED
A	INITIAL RELEASE	08-22-02	
B	CO 031 Drafting Update	01-17-06	Rick C.

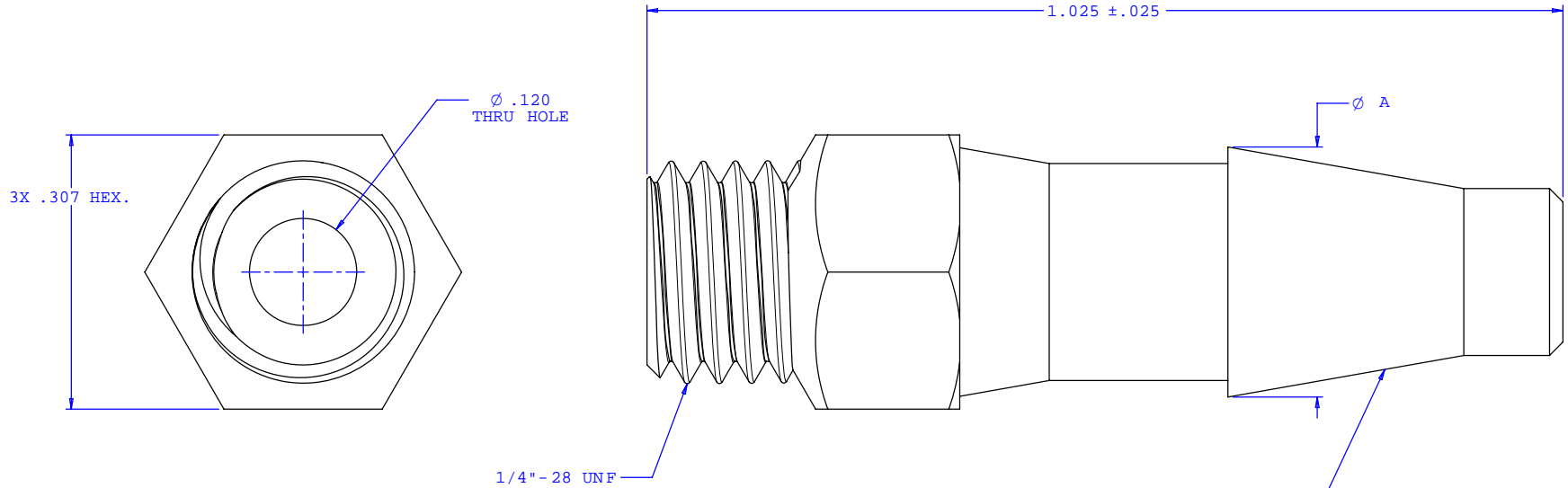

INSTRUMENT QUALITY PART. NO PARTING LINE PERMITTED ON THIS CONICAL SURFACE

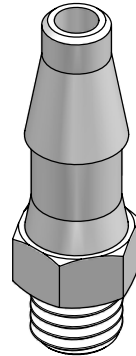

Dimension	Material Specific Tolerances							
	Acetal	Nylon	PP	ABS	PC	PVC	Polysulfone	J1A
A	.280	.280	.280	.280	.280	.280	.280	.275
B								
C								
D								
E								
F								

UNLESS OTHERWISE SPECIFIED DIMENSIONS ARE IN INCHES TOLERANCES ARE:		VALUE PLASTICS, INC.	
FRACTIONS ±	DECIMALS ±	ANGULAR ±1°	PART NUMBER: S50
.XX ± .01	.XXX ± .005	.XXXX ± .001	DESCRIPTION: 1/4-28 UNF Thread with 5/16" Hex to Classic Series Barb, 3/16" (4.75 mm) ID Tubing
DO NOT SCALE DRAWING			REV. B
DRAWN BY: Frank Lombardi	DATE: 10-29-05	SIZE: B SCALE: NTS	DRAWING NUMBER: 1007765
Engineer/Manager: Rick Cairns		© 2005 VALUE PLASTICS, INC. SHEET: 1 OF 1	

FOR REFERENCE ONLY