

- NOTES:
- FOR ADDITIONAL DETAILS, PLEASE CONTACT VP PRODUCT DEVELOPMENT
  - DIMENSIONS MARKED  $\varnothing$  ARE CONTROL DIMENSIONS
  - ALL EXTERIOR SURFACES HAVE A 20 Ra MICROINCH SURFACE FINISH OR BETTER
  - ALL INTERIOR SURFACES HAVE A 15 Ra MICROINCH SURFACE FINISH OR BETTER
  - VALUE PLASTICS SFMX SERIES PRODUCT MOUNTING FLANGES ARE DESIGNED TO COMPLY WITH ISO:2852:1993 (E) FLANGE AND GASKET GROOVE DIMENSIONAL GUIDELINES. PRODUCT TOLERANCES COMPLY WITH VALUE PLASTICS ENGINEERING STANDARDS OR AS SPECIFIED ON THE PRINT. ALL INTERIOR AND EXTERIOR SURFACE FINISHES COMPLY WITH ISO:2852:1993 (E) SURFACE ROUGHNESS GUIDELINES.

REVISIONS			
REV.	DESCRIPTION	DATE	APPROVED
A	INITIAL RELEASE	01-12-09	S.N.R
B	MODIFIED TOLERANCE PER ECO 112	02-23-09	S.N.R

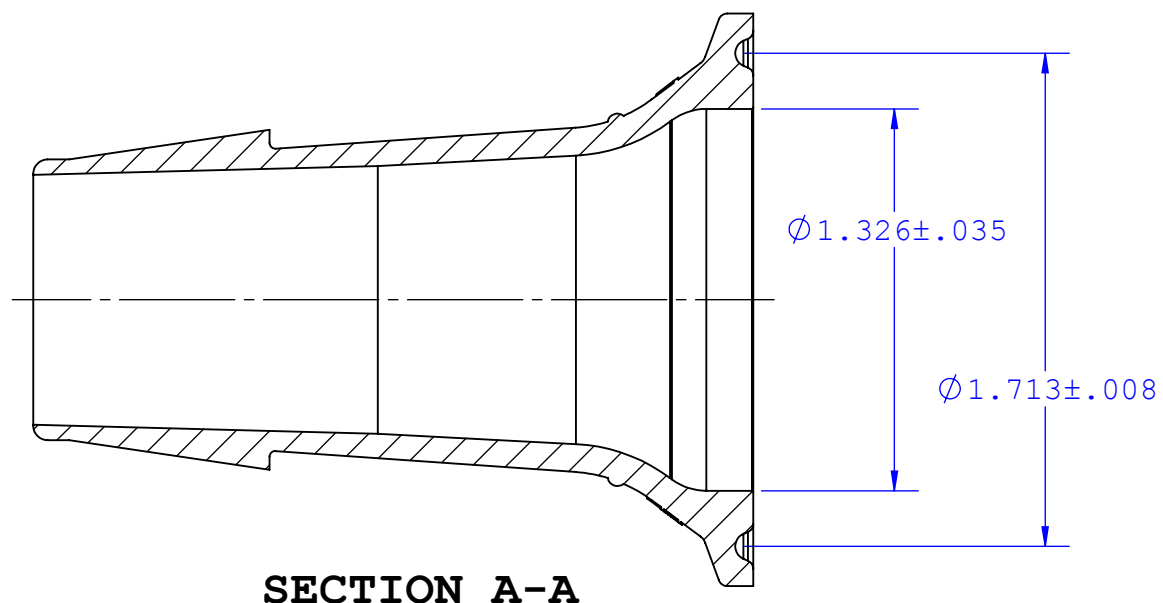

INSTRUMENT QUALITY PART. NO PARTING LINE PERMITTED ON THIS CONICAL SURFACE.

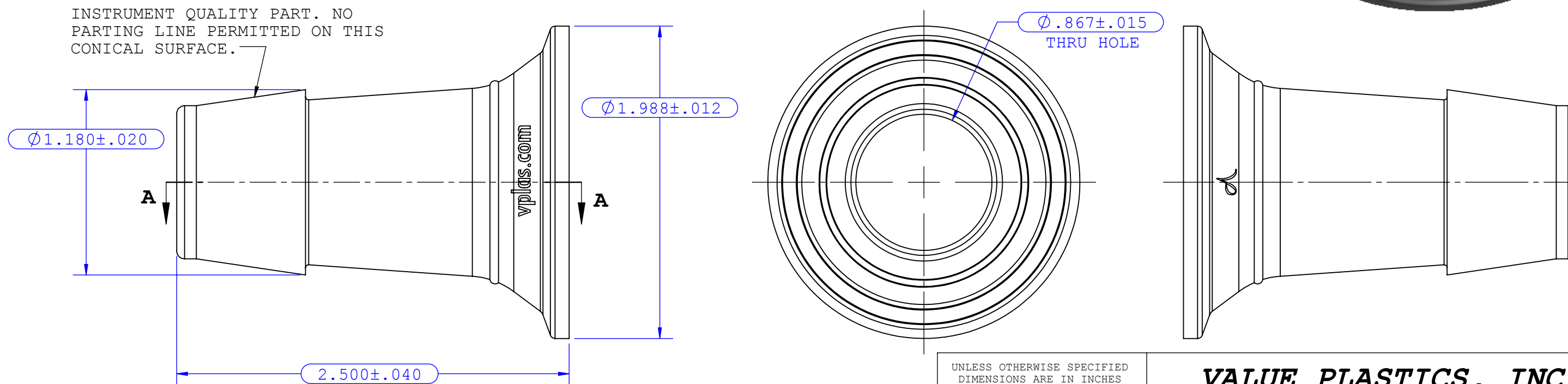

UNLESS OTHERWISE SPECIFIED  
DIMENSIONS ARE IN INCHES  
TOLERANCES ARE:

FRACTIONS	DECIMAL	ANGULAR
$\pm$	.XX $\pm .01$	$\pm 1^\circ$
	.XXX $\pm .005$	
	.XXXX $\pm .001$	

DO NOT SCALE DRAWING

**VALUE PLASTICS, INC**

PART NUMBER: SFMX6110  
DESCRIPTION: Sanitary Fitting, Maxi Flange to 600 Series Barb, 1" (25.4 mm) Tubing ID

DRAWN BY: Pete L.	DATE: 2/23/2009	SIZE: <b>B</b>	SCALE: NTS	VER:	DWG. NO. 1013883	REV B
----------------------	--------------------	-------------------	---------------	------	---------------------	----------

NEW PRODUCT DEVELOPMENT MGR:  
R. Narayanan

© 2008 VALUE PLASTICS, INC SHEET: 1 OF 1

**FOR REFERENCE ONLY**