

- NOTES:
- FOR ADDITIONAL DETAILS, PLEASE CONTACT VP PRODUCT DEVELOPMENT
 - DIMENSIONS MARKED  ARE CONTROL DIMENSIONS
 - ALL EXTERIOR SURFACES HAVE A 20 Ra MICROINCH SURFACE FINISH OR BETTER
 - ALL INTERIOR SURFACES HAVE A 15 Ra MICROINCH SURFACE FINISH OR BETTER
 - VALUE PLASTICS SFMX SERIES PRODUCT MOUNTING FLANGES ARE DESIGNED TO COMPLY WITH ISO:2852:1993 (E) FLANGE AND GASKET GROOVE DIMENSIONAL GUIDELINES. PRODUCT TOLERANCES COMPLY WITH VALUE PLASTICS ENGINEERING STANDARDS OR AS SPECIFIED ON THE PRINT. ALL INTERIOR AND EXTERIOR SURFACE FINISHES COMPLY WITH ISO:2852:1993 (E) SURFACE ROUGHNESS GUIDELINES.

REVISIONS			
REV.	DESCRIPTION	DATE	APPROVED
A	INITIAL RELEASE	3-15-07	S.N.R
B	CHANGED DIMENSION AND MODIFIED TOLERANCE	6-11-07	S.N.R
C	PER ECO 077	10-29-08	S.N.R
D	MODIFIED NOTES AND TOLERANCES	12-05-08	S.N.R

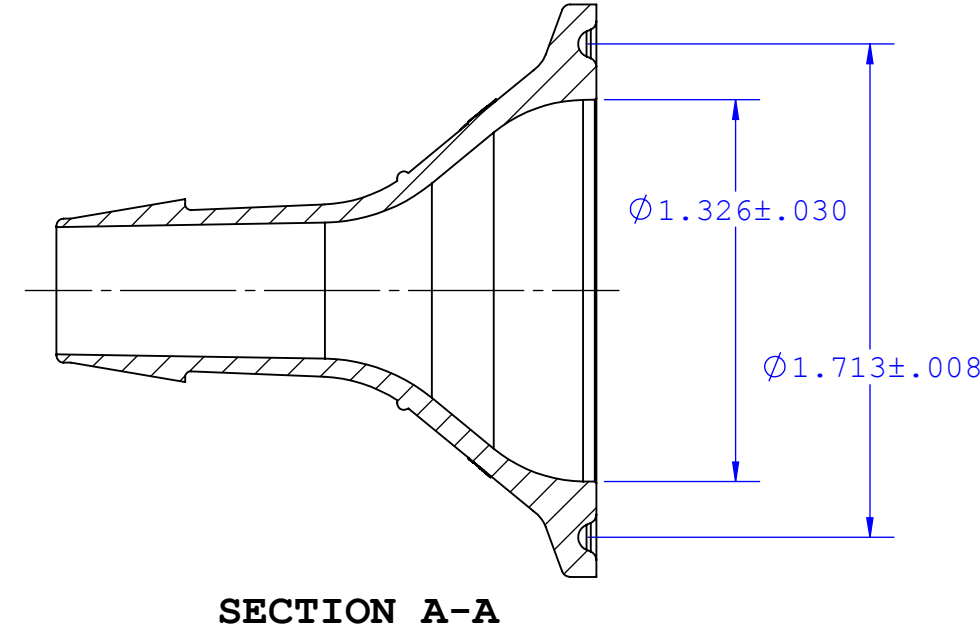

INSTRUMENT QUALITY PART. NO PARTING LINE PERMITTED ON THIS CONICAL SURFACE.

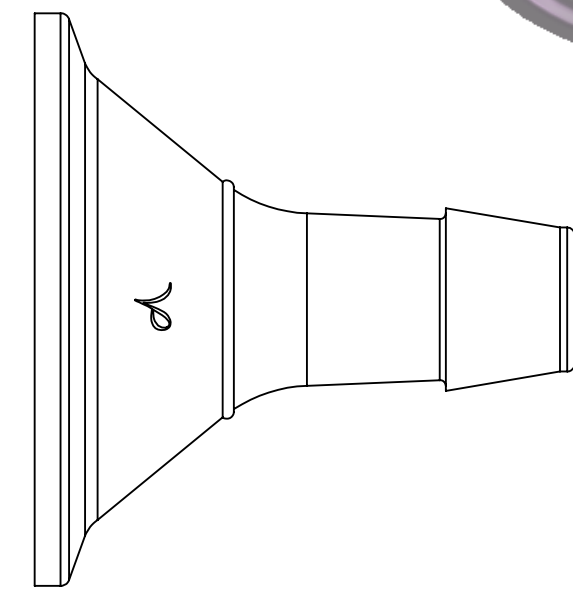
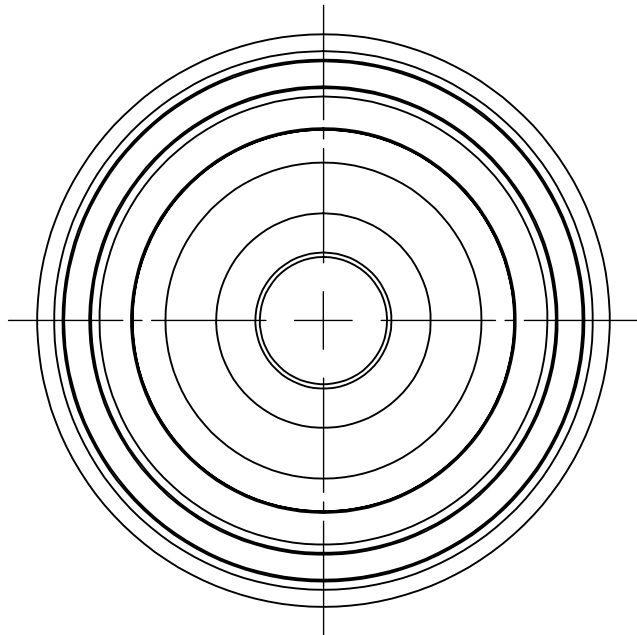
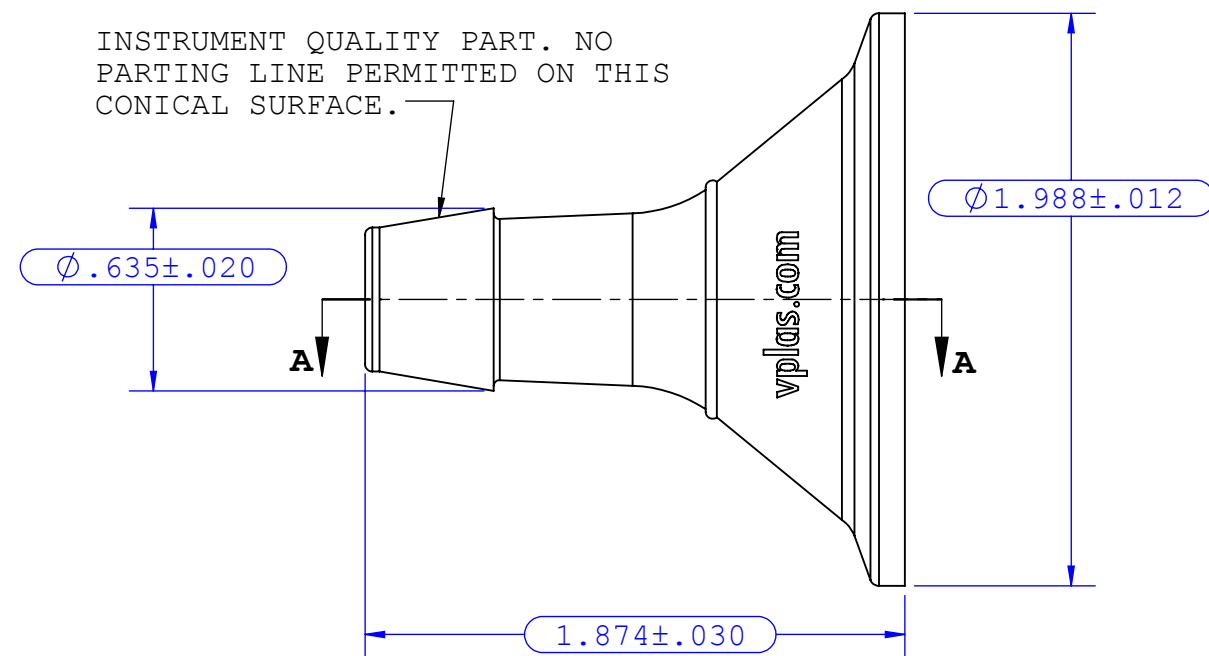

UNLESS OTHERWISE SPECIFIED DIMENSIONS ARE IN INCHES TOLERANCES ARE:		VALUE PLASTICS, INC			
FRACTIONS ±	DECIMAL .XX ±.01 .XXX ±.005 .XXXX ±.001	ANGULAR ± 1°	PART NUMBER: SFMX680		
DO NOT SCALE DRAWING			DESCRIPTION: Sanitary Fitting, Maxi Flange to 600 Series Barb, 1/2" (12.7 mm) Tubing ID		
DRAWN BY: M.Lalouette	DATE: 12/5/2008	SIZE: B	SCALE: NTS	VER: 1010483	REV: D
© 2007 VALUE PLASTICS, INC					SHEET: 1 OF 1