

NOTES: FOR ADDITIONAL DETAILS, PLEASE CONTACT VP CUSTOMER SERVICE  
 DIMENSIONS MARKED  ARE CONTROL DIMENSIONS

REVISIONS			
REV.	DESCRIPTION	DATE	APPROVED
A	INITIAL RELEASE	02-11-03	
B	CO 046 Drafting Update	08-22-06	Rick C.
C	ECO 150- Make PP and Nylon Material Specific	10-14-09	Rick C.

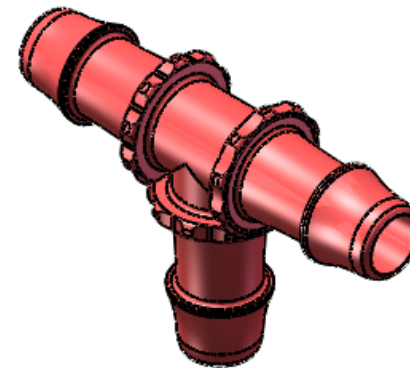
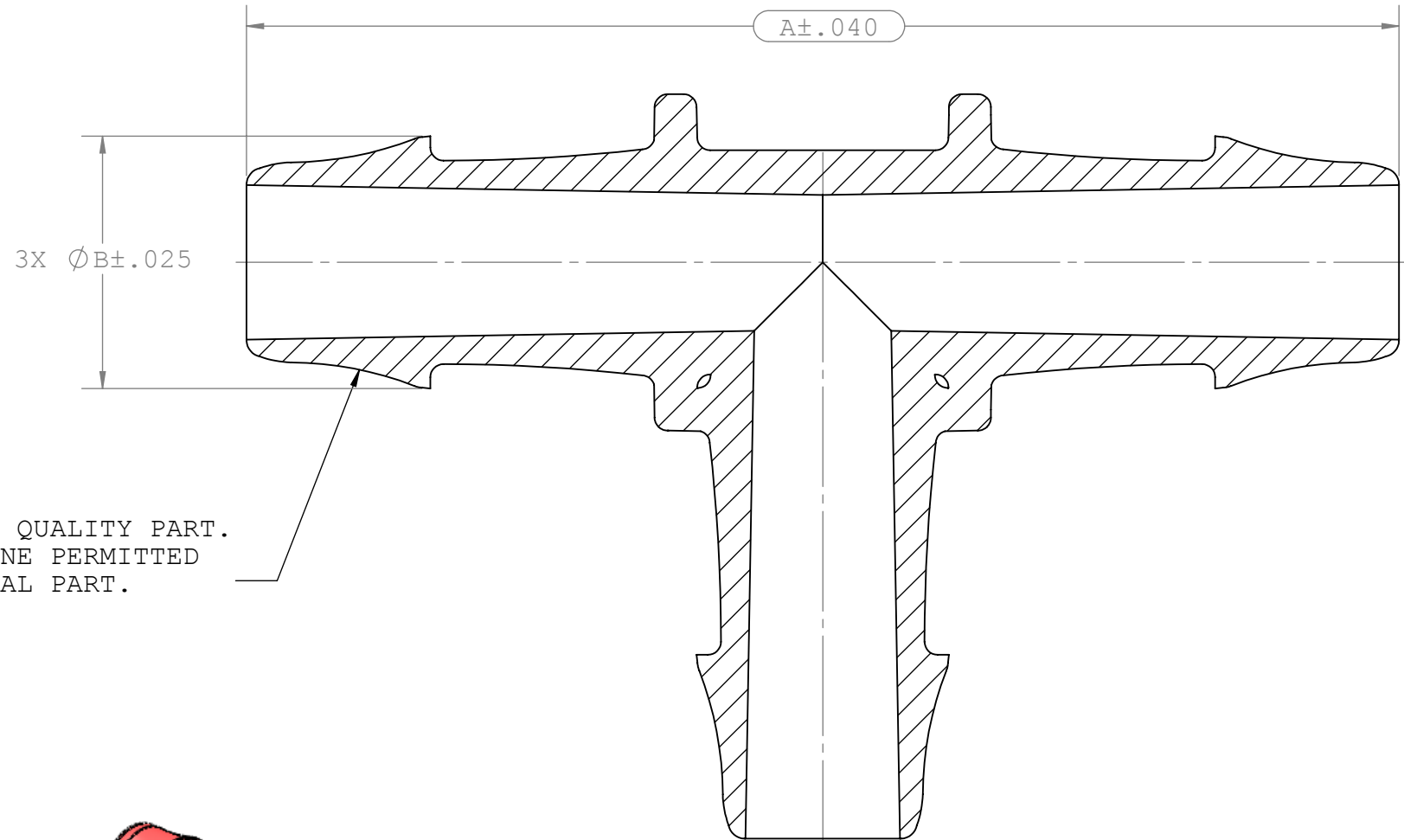
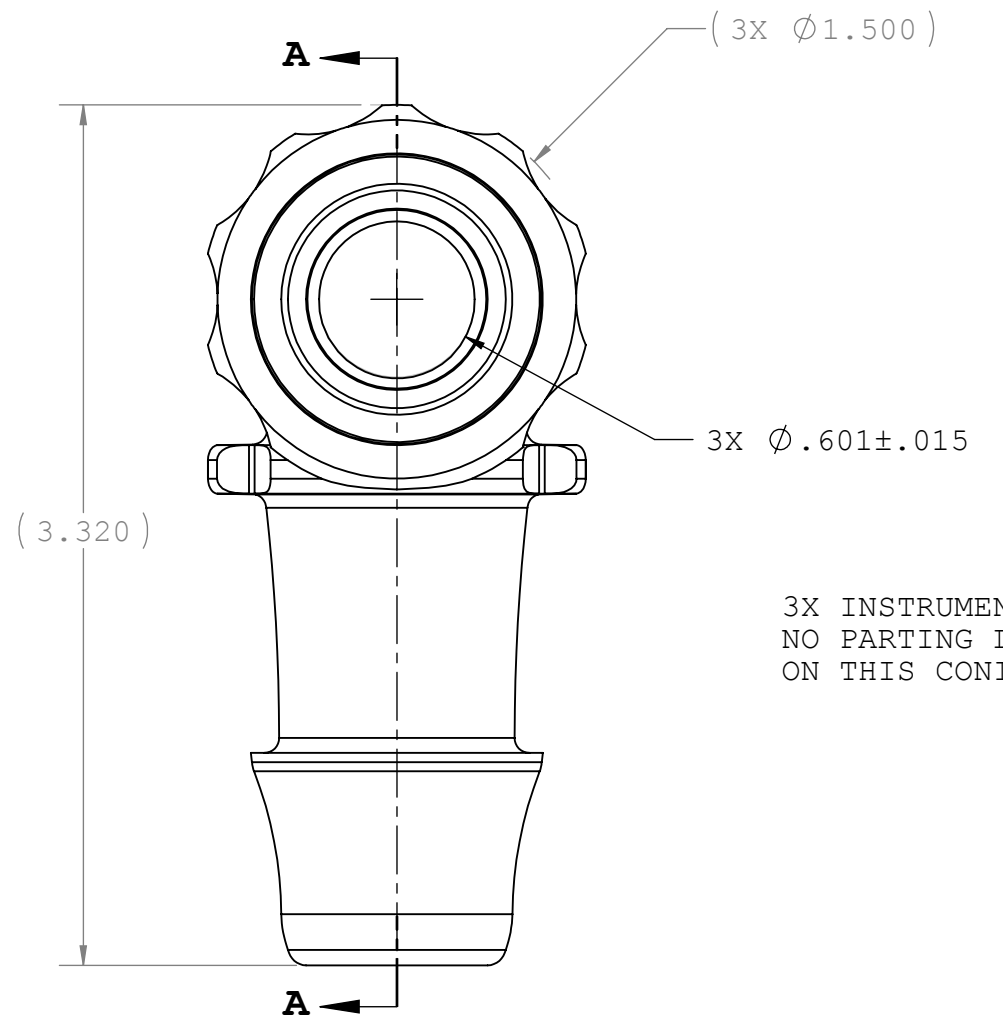

SECTION A-A

Dimension	Material Specific Tolerances							
	Acetal	Nylon	PP	ABS	PC	PVC	Polysulfone	Kynar
A		5.072	5.092					
B		1.103	1.113					
C								
D								
E								
F								

UNLESS OTHERWISE SPECIFIED DIMENSIONS ARE IN INCHES TOLERANCES ARE:		<b>VALUE PLASTICS, INC</b>			
FRACTIONS	DECIMAL				
± .XX	± .01	± 1°	DESCRIPTION:	Tee Connector with 500 Series Barb, 1" (25.5mm) ID Tubing	
± .XXX	± .005		SIZE:	B	
± .XXXX	± .001		SCALE:	NTS	
DO NOT SCALE DRAWING		VER:	DWG. NO.	1008939	
DRAWN BY:	DATE:	REV:		C	
randy.sakurada	8/11/2010				
ENGINEERING MGR:		© 2009 VALUE PLASTICS, INC		SHEET: 1 OF 1	
R. Cairns					

**FOR REFERENCE ONLY**