

NOTE: FOR MORE DETAILS SEE YOUR V.P.CUSTOMER SERVICE REP.

REVISIONS			
REV.	DESCRIPTION	DATE	APPROVED
A	INITIAL RELEASE	11-06-97	
B	CO 024 Drafting Update	10-04-05	Rick C.

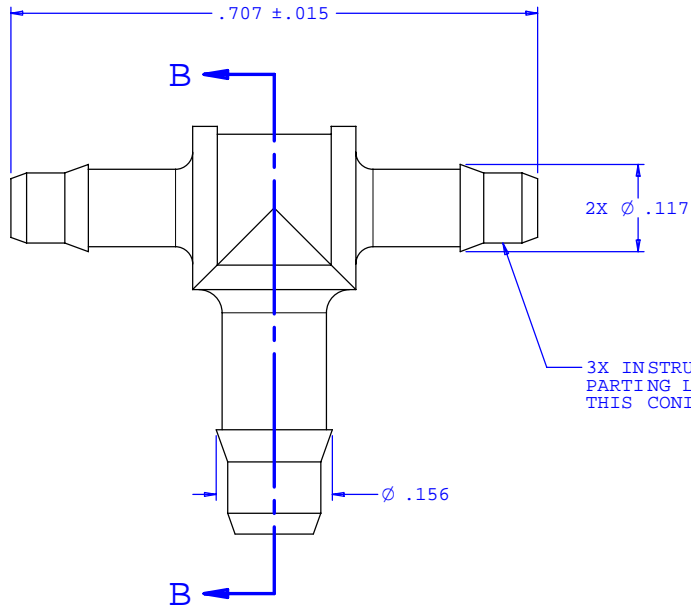

3X INSTRUMENT QUALITY PART. NO PARTING LINE PERMITTED ON THIS CONICAL SURFACE

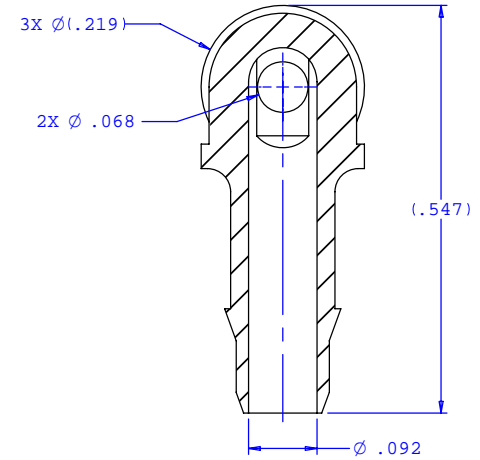

SECTION B-B

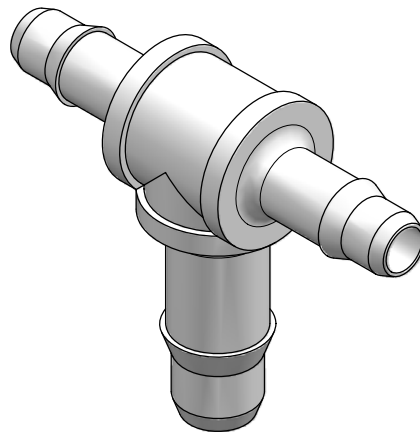

UNLESS OTHERWISE SPECIFIED DIMENSIONS ARE IN INCHES TOLERANCES ARE:		<b>VALUE PLASTICS, INC.</b>	
FRACTIONS ±	DECIMALS .XX ±.01 .XXX ±.005 .XXXX ±.001	ANGULAR ±1°	PART NUMBER: <b>T420-430</b>
DO NOT SCALE DRAWING		DESCRIPTION: Tee Reduction Connector with 400 Series Barbs, 3/32" (2.25 mm) and 1/8" (3 mm) ID Tubing	
DRAWN BY: <b>Frank Lombardi</b>	DATE: <b>07-29-05</b>	SIZE: <b>B</b>	SCALE: <b>NTS</b>
Engineer/Manager: <b>Rick Cairns</b>		DRAWING NUMBER: <b>1007233</b>	REV. <b>B</b>
© 2005 VALUE PLASTICS, INC.			SHEET: 1 OF 1

**FOR REFERENCE ONLY**