

NOTES: FOR ADDITIONAL DETAILS, PLEASE CONTACT VP CUSTOMER SERVICE

REVISIONS			
REV.	DESCRIPTION	DATE	APPROVED
A	Initial Release	07/29/2010	R. Cairns

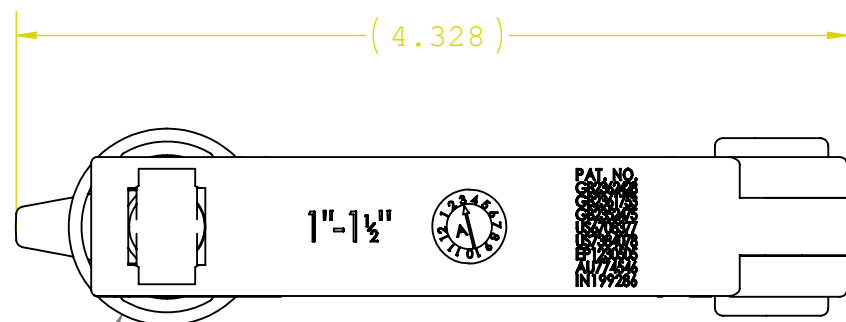
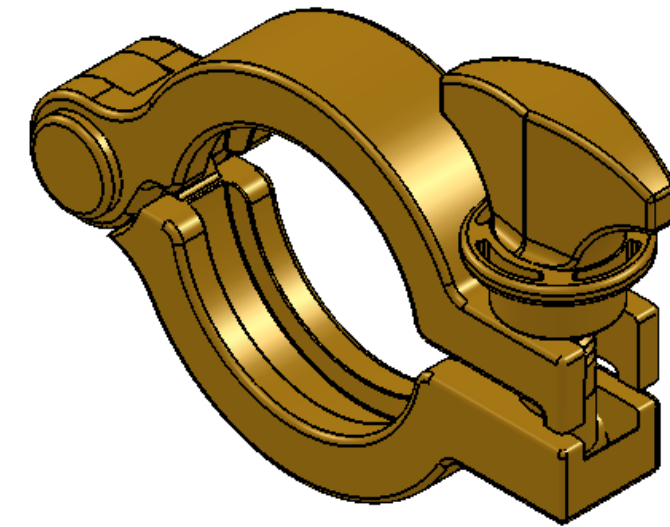
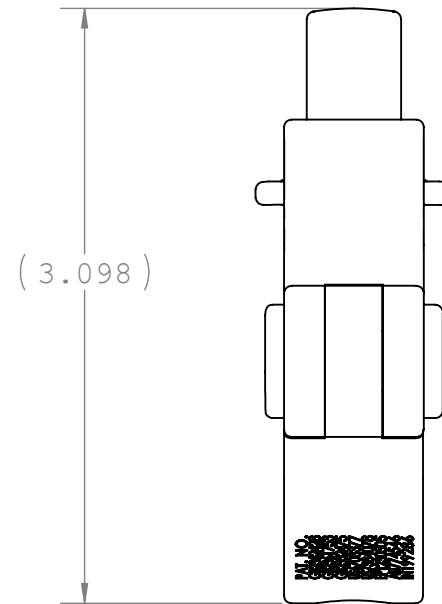
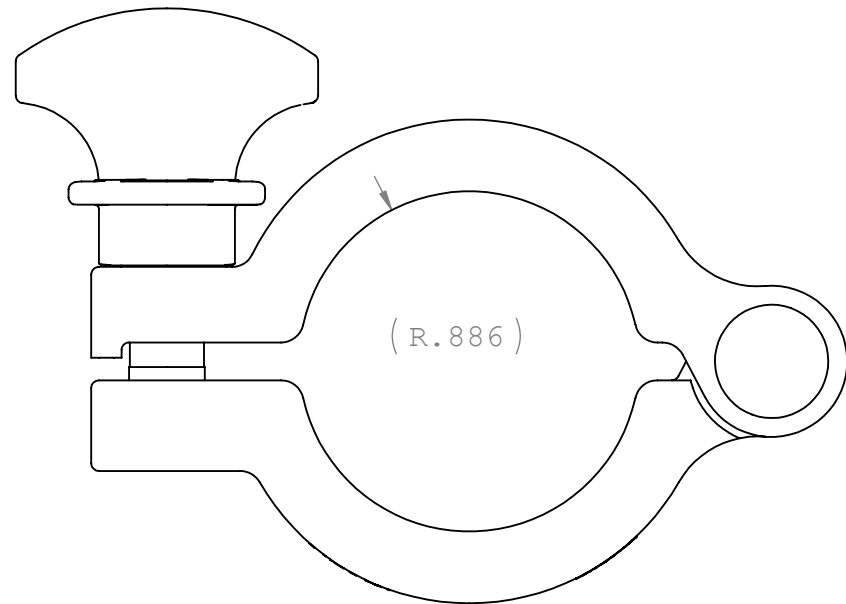
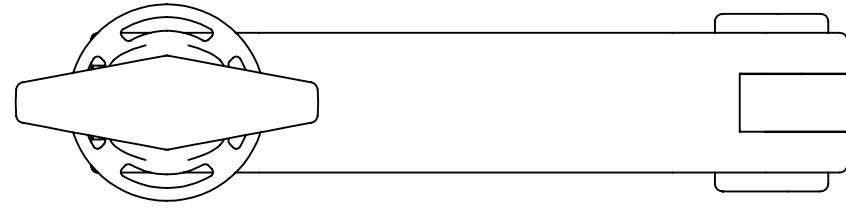

(Ø1.024)

UNLESS OTHERWISE SPECIFIED DIMENSIONS ARE IN INCHES TOLERANCES ARE:		VALUE PLASTICS, INC			
FRACTIONS DECIMAL ANGULAR ± .XX ±.01 ± 1° .XXX ±.005 .XXXX ±.001		PART NUMBER: VNG150WHT			
DO NOT SCALE DRAWING		DESCRIPTION: Clamp, Maxi Flange, 1" (25.4 mm) to 1.5" (38.1 mm), Glass Reinforced White Nylon			
DRAWN BY: shannond	DATE: 7/30/2010	SIZE: B	SCALE: NTS	VER:	DWG. NO. 1018294
MANAGER: R. Cairns		© 2010 VALUE PLASTICS, INC			REV A
				SHEET: 1 OF 1	

FOR REFERENCE ONLY